

P/N: FACCF12V-253Y0R5

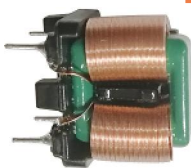

PAIRUI
www.fuantronics.net

Outline Dimensions(Unit:mm)

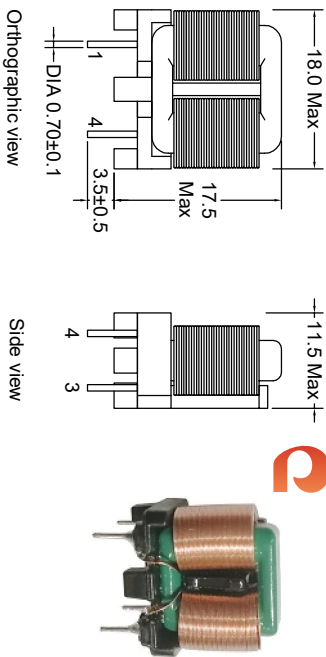

Electrical Schematic

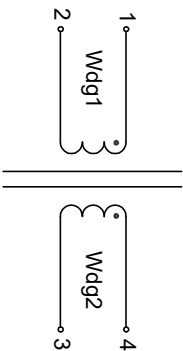

Recommended Soldering Temperature Graph.

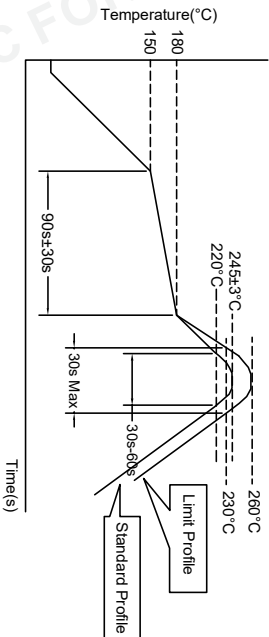

Process	Standard Profile	Standard Profile
Pre-heating	150~180°C,90s±30s	
Heating	above 220°C,30s-60s	above 240°C,30s Max
Peak temperature	245°C±3°C	260°C,±0s
Cycle of reflow	2 times	2 times

Electrical Characteristics(at 20°C)

Inductance : L1-2=4-3= 25.0mH Min,at 1KHz,0.25V.
 Inductance balance : L(1-2)-(4-3)= 200uH Max,at 1KHz,0.25V.
 Rated current: 0.50Amps.
 Turns Ratio : Wdg1:Wdg2= 1:1±2%,at 20KHz,1V.
 Hipot : Pri-Sec : 1500VAC/5mA/2Second.

REMARK:

1. Product Vacuum impregnation.

List of UL Certificate:

Part Name	Mat'l Description	Supplier	UL Number
Base	SQ12/T375HF	Chang Chun Plastics Co Ltd	E59481
Copper wire	SFT-UEW-H	Ningbo Jintian New Material Co Ltd	E227047
Core	SQ1212-H10K	ShanDong HengRui Magnet Technology Co Ltd	N/A
Varnish	T-4260(a)	Suzhou TaiHu Electric Advanced Material Co Ltd	E228349

***Weight:Approx 5.5g.

REV	DESCRIPTION	APPD	DATE	Tianchang Fuan Electronic Co Ltd www.fuantronics.net TEL: +86-550-7814888 FAX:+86-550-7831133	<p>Tolerances unless otherwise specified: (X)±0.50 (XX)±0.25 Unit of measurement: mm</p>	Make: Qiumei Liu Checked: Beson. zhan Approved: Anson. zhan	DRAWING TITLE CCF12V Current-compensated frame core double chokes	Customer P/N: Document/Rev: 00 Specification Sheet: 1 of 1
-----	-------------	------	------	--	--	---	---	--